

M101S-EX

10.1" ATEX Rugged Tablet with Intel® Core™ i5-7200U



KEY FEATURES

- Allows cross-zone operations in hazardous and explosive environments
- Ex Certificate: Class I Division 2 (CID2), ATEX/IECEx Zone 2
- 7th Gen Intel® Core™ i5-7200U Kaby lake processor
- 10.1" 1920 x 1200 IPS LED Panel with direct optical bonding
- Sunlight readable with anti-glare solution, fully ATEX tablet
- Hot-swappable battery design with optional High capacity battery pack
- IP65 waterproof and dustproof, MIL-STD-810G shock, vibration and drop resistance

INTRODUCTION

Winmate ATEX Rugged Tablet Series is designed for hazardous and explosive environments, offering reliable performance with support for multiple operating systems, including Windows and Android. Featuring sunlight-readable displays with direct optical bonding, IP65-rated protection, and MIL-STD compliance, these tablets ensure durability and usability in challenging conditions. Certified for Class I Division 2 (CID2) and ATEX/IECEx Zone 2, they enable seamless cross-zone operations. Hot-swappable batteries and versatile connectivity enhance productivity across industrial and field applications.

OVERVIEW



Rugged Design with a High Level of Protection

Winmate offers intrinsically safe Windows tablet M101S-EX with ATEX, IECEx Zone 2, and CID2 compliances, which can be used in hazardous and non-hazardous environments. It is a system solution for multiple applications, including chemicals, distilleries, petrol, and many more.

Like other Winmate rugged tablets, our intrinsically safe Windows tablet is developed with built-in TPM 2.0 and Kensington Lock for hardware-based security, securing information saved on a computer, as intrinsically safe Windows tablet computers typically hold vast amounts of data.

Incredible Performance with Intel's CPU

The M101S-EX uses Intel® Core™ i5-7200U Processor 2.5 GHz (turbo to 3.1 GHz) with an efficient cooling system to provide stable performance and low power consumption. The M101S-EX supports the Windows® IoT Enterprise operating system to meet mobile data collection needs in hazardous and non-hazardous environments.





Mobility in the harshest environments

Winmate's ATEX Windows tablet is designed with simplicity for a challenging job. Not only can it be effortlessly held in one hand. It also features a wide range of networking options and numerous interfaces. Data gathered on the field can be shared in real-time through wireless LAN, BT, and optional cellular communications networks. The M101S-EX tablet has front and rear cameras, an optional RFID Reader and barcode reader for quick data collection, a hot-swappable battery design, or an optional high-capacity battery for long-lasting power performance.

Rugged Design in Mobile Form Factor

The M101S-EX rugged tablet can be effortlessly held in one hand and is also designed to be tough and rugged, withstanding shock, vibration, and dropping up to 4 ft. to concrete according to MIL-STD-810G standards for operations in some of the harshest environments. With all-around rubber edges and covered I/O ports, the M101S-EX is IP65 dust-tight and waterproof. Ready for use in wet and dusty environments.



Brilliant 10.1" Display with Ultimate Touch Capability

The 10.1" screen of M101S-EX features projected capacitive (PCAP) multi-touch for the best user experience and allows switching windows, taking snapshots, zooming in, and rotating objects easily to take full advantage of the touch interface. With the optical bonding on its panel, the tablet is readable under bright sunlight, thus able to support various field works.

SPECIFICATIONS

Display

Resolution	1920x1200	Size	10.1 inches
Contrast Ratio	800:1	Panel Brightness	800.0 nits
View Angles	85,85,85,85	Type	Projected Capacitive Multi Touch
Viewability	Anti-Glare touch treatment	Bonding	Optical Bonding for Sunlight Viewability

System Specification

Processor	Intel Core i5-7200U 2.5GHz (up to 3.1GHz) Intel Core i5-7300U 2.6GHz (up to 3.5GHz) (Optional)	Memory	8GB DDR4 SDRAM 16GB DDR4 SDRAM (Optional)
Storage	256GB SSD Additional storage available with micro SDXC card slot 512GB SSD (Optional)	Security	Trusted Platform Module (TPM) 2.0 Kensington Lock
Operating System	Windows 10 IoT Enterprise (64 bit)	WLAN	Support
BT	Support	WWAN	4G LTE (Optional)
GNSS	GPS, GLONASS	RFID	HF RFID reader 13.56 MHz (Optional)
Sensors	Light sensor/ G-sensor / Gyro		

Camera

Front Camera	2MP Front Camera	Rear Camera	8MP Rear Camera with auto-focus and LED light
---------------------	------------------	--------------------	---

Mechanical

Dimension	271.8 x 197.2 x 21 mm (10.7 x 7.76 x 0.83 inches)	Weight	1.25 kg (2.75 lbs) with standard battery, 1.45 kg (3.2 lbs) with optional high capacity battery
------------------	---	---------------	--

Cooling System	Fan Design
-----------------------	------------

IO Ports

USB Port	1 x USB 3.0 (Type A), 1 x USB 3.0 (Type C)	SD Card Slot	1 x Micro SDXC slot
SIM Card Slot	1 x Micro SIM card slot	Video	1 x Micro HDMI (Optional)
Audio	1 x Audio combo 3.5mm audio combo jack Dual Digital Mic With Noise Cancellation Dual Speaker	Indicator	4x LED Indicator for Power, Battery, HDD, RF status
Docking Connector	1 x 19-pin docking connector		

Environment

Operating Humidity	10% to 90% RH, non-condensing	Operating Temperature	-10°C to 50°C
Storage Temperature	-30°C to 70°C (-22°F to 158°F)	Shock	MIL-STD-810G Method 516.6 Procedure I
Vibration	MIL-STD-810G Method 514.6 Procedure I	IP rating	IP65
Drop	MIL-STD-810G Method 516.6, 4 ft		

Certification

Certification	CE, FCC Hazardous Location Safety: IECEx Class I, Zone 2, Ex ic IIC T4 Gc ATEX Class I, Zone 2, II 3G Ex ic IIC T4 Gc Class I, Division 2, Groups A, B, C, D, T4A
----------------------	---

Security Function

SOTI MobiControl	SOTI MobiControl Compliance	Kensington Lock	Kensington Lock Support
------------------	-----------------------------	-----------------	-------------------------

Control

Button	1 x Power, 1 x Home 2 x volume key 2 x Programmable function Keys
--------	---

Power

Battery	Hot-swappable 7.4V, typ. 5140 mAh LiPolymer Battery (2S1P)	Battery Operating Time	Standard. Battery: 8 hours
Power Rating	19V DC	Adapter	100-240V, 50-60Hz / 19V DC

Accessory

Accessory	Adapter and Power Cord Capacitive Stylus Standard Battery	Optional Accessory	Desk Dock (Optional) Vehicle Dock (without VGA output) (Optional) Vehicle Cradle (Optional) Vehicle Charger (Optional) High Capacity Battery (Optional) Battery Charger (Optional) Hand Strap (Optional) Shoulder Strap (Optional) Carry Bag (Optional) VESA Mount Kit (Optional)
-----------	---	--------------------	--

Barcode Scanner

Barcode Scanner	1D/2D barcode reader (Optional)
-----------------	---------------------------------

DIMENSIONS UNIT:MM

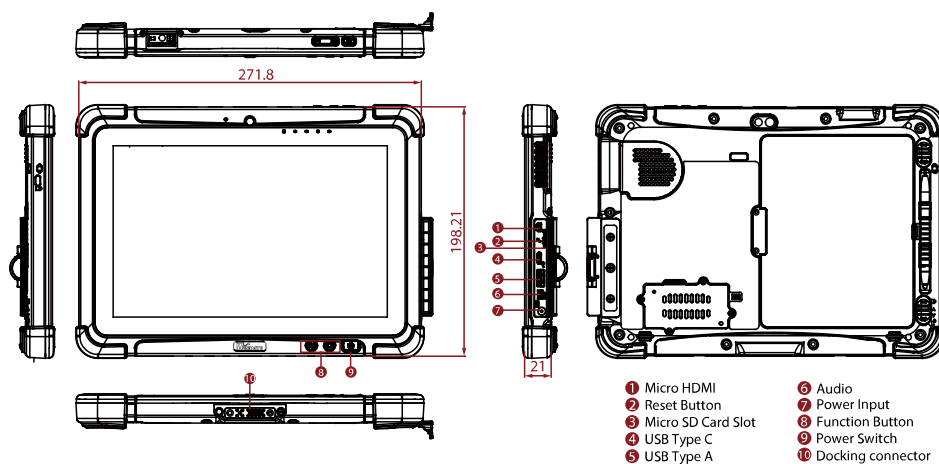

NOTE

- 1.This is a simplified drawing and some components are not marked in detail.
- 2.Please contact our sales representative if you need further product information.
- 3.All specifications are subject to change without prior notice.
- 4.The product shown in this datasheet is a standard model.For diagrams that contain customized or optional I/ O, please contact the Winmate Sales Team for more information.