

Features

- Industrial Display
- Flat front panel touch screen
- Fanless design
- Wide range DC 9~36V power input
- IP66 compliant front panel / IP69K (option)
- VGA/DVI-D/HDMI/DP input
- System power LED light
- High Brightness LCD and Auto Dimming for option
- Support protective AR glass for option (non-touch version)

Specifications

I/O Port	
VGA	1 x VGA
DVI	1 x DVI-D
DP	1 x DP
HDMI	1 x HDMI
Audio	1 x Audio line-in phone jack
OSD Control Membrane	OSD at rear side On board controller, extendable key pad from connector
Power	1 x 3-pin terminal block for DC 9~36V power input
Others	1 x USB type B for touch control Optional I/O: 1 x Speaker 1 x RS-232 DB-9 for touch control

Display	Standard	High Brightness Optional
Display Type	17" TFT LCD	17" TFT LCD
Max. Resolution	1280 x 1024	1280 x 1024
Max. Color	16.2M	16.7M
Luminance (cd/m ²)	350	1000
View Angle	170(H) / 160(V)	170(H) / 160(V)
Contrast	1000:1	1000:1
Backlight Lifetime	30,000 hrs	50,000 hrs

Touch Screen	
Type	Resistive Touch (For ARCDIS-117AR model) Projected Capacitive Touch (For ARCDIS-117AP model) Glass-AR (For ARCDIS-117AG model)
Interface	USB default (Resistive / Projected Capacitive Touch) RS-232 Option (Resistive Touch)
Light Transmission(%)	Resistive Touch : over 80% Projected Capacitive Touch : over 90%

Power	
Power Input	DC 9~36V
Power Consumption	ARCDIS-117AP: 27.3W

Mechanical	
Construction	Aluminum die-casting chassis
Mounting	Panel mount / VESA mount 100 x 100
IP Rating	IP66 compliant front panel / IP69K(option)
Dimensions (WxHxD)	439 x 348 x 64.8 mm
Net Weight	5.9 kg

Dimensions

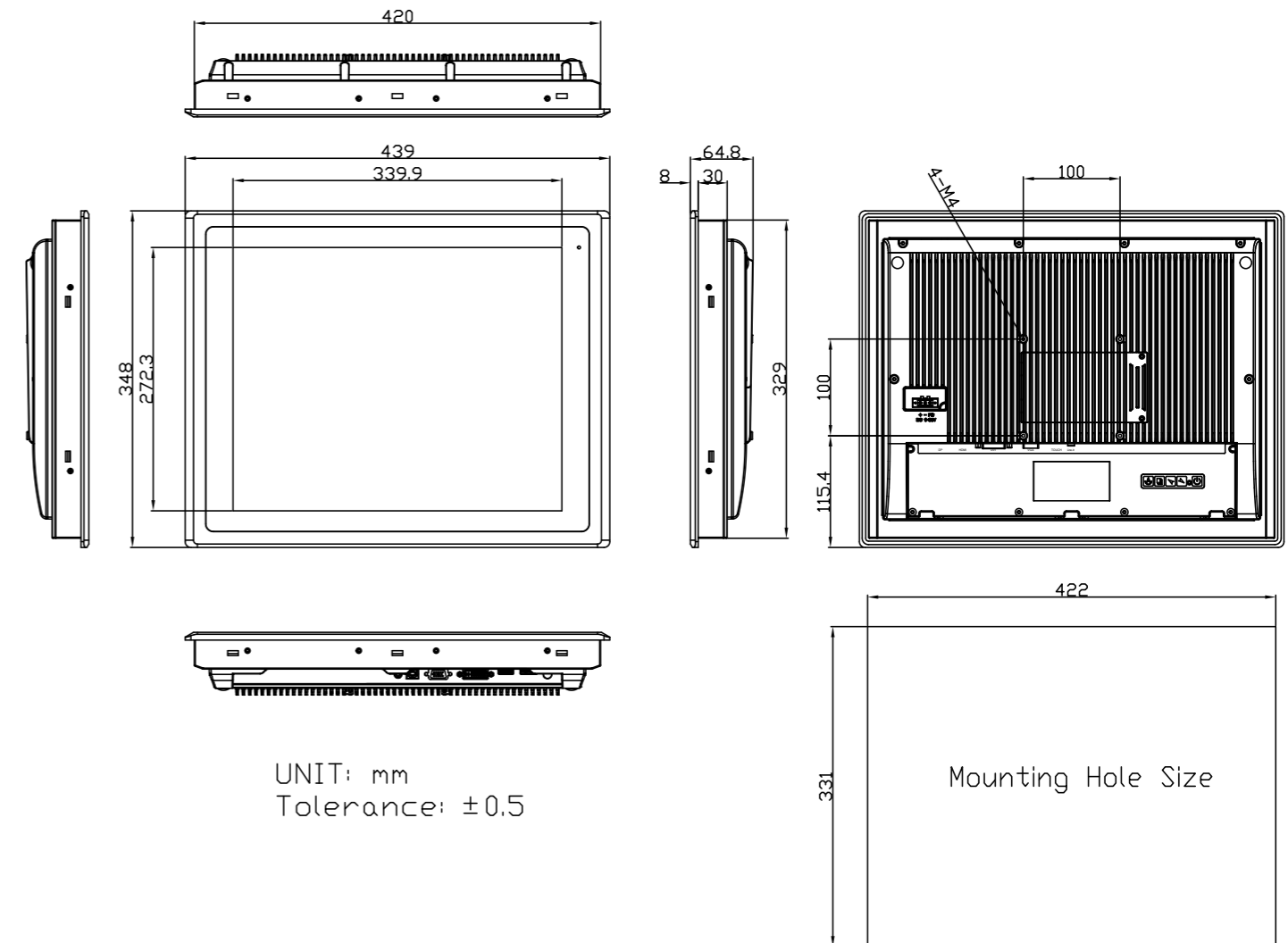

UNIT: mm
Tolerance: ±0.5

Environmental	
Operating Temperature	0~50°C
Storage Temperature	-30~70°C
Storage Humidity	10 to 90% @ 40°C, Non-condensing
Certificate	CE/FCC, Class A

Ordering Information	
ARCDIS-117AR-01	17" SXGA FPD Industrial display, Resistive touch window, VGA, DVI-D, HDMI, and DP input, 5 keys Rear OSD, DC 9~36V power input with adapter, Aluminum Die-casting Chassis
ARCDIS-117AP-01	17" SXGA FPD Industrial display, Projected Capacitive touch screen, VGA, DVI-D, HDMI, and DP input, 5 keys Rear OSD, DC 9~36V power input with adapter, Aluminum Die-casting Chassis



VIVATECH LLC
Sharjah Media City, Sharjah, UAE
Call: +97 1589584527
Call: +91 9004784527
Email : sales@vivatech.ae
Website : www.vivatech.ae