

## Features

- 15" TFT-LCD
- Intel 6th Gen. Core i3/i5 Processor
- SUS 316 Stainless Steel
- Total IP66 Grade with M12 Waterproof Connector
- Variety of IO applications
- Wide range DC 9~36V Power Input
- Support Panel Mount & VESA Mount
- Support Projected Capacitive Touch
- Full Flat Bezel and Fanless Design
- ATEX Zone2, IECEx and C1D2 Certified

## Specifications

System	
CPU	Onboard 6th Gen Intel Core i3/i5 processor
System Chipset	SoC
Memory	1 x 260-pin SO-DIMM up to 16GB DDR4 2400MHz

IO Port	
USB	1 x M12 8-pin for 2 x USB 2.0 with waterproof cover and chain
Serial / Parallel	1 x M12 8-pin for COM1, RS-232/422/485, default RS-232, with waterproof cover and chain
LAN	2 x M12 8-pin for LAN with waterproof cover and chain
Graph	1 x M12 8-pin for VGA with waterproof cover and chain
Power	1 x M12 3-pin for DC power connector with waterproof cover and chain

Storage Space	
HDD	1 x 2.5" HDD or SSD space 1 x mSATA space

Expansion	
Expansion Slot	1 x Mini-PCIe (full size)

Display	Standard	High Brightness Optional
Display Type	15" TFT-LCD	15" TFT-LCD
Max. Resolution	1024 x 768	1024 x 768
Max. Color	16.2M	262K
Luminance (cd/m <sup>2</sup> )	450	1000
View Angle	160(H) /150(V)	160(H) /150(V)
Contrast	800:1	800:1
Backlight Lifetime	50,000 hrs	50,000 hrs

Touch Screen	
Type	Projected Capacitive Touch
Interface	USB
Light Transmission(%)	90%

Power	
Power Input	DC 9~36V
Power Consumption	AEx-915AP: 27W

Mechanical	
Construction	316 stainless steel chassis
Mounting	VESA mount 100 x 100, Panel mount (option)
IP Rating	Total IP66
Dimensions	399 x 324 x 70 mm
Net Weight	9.7 kg

## Dimensions

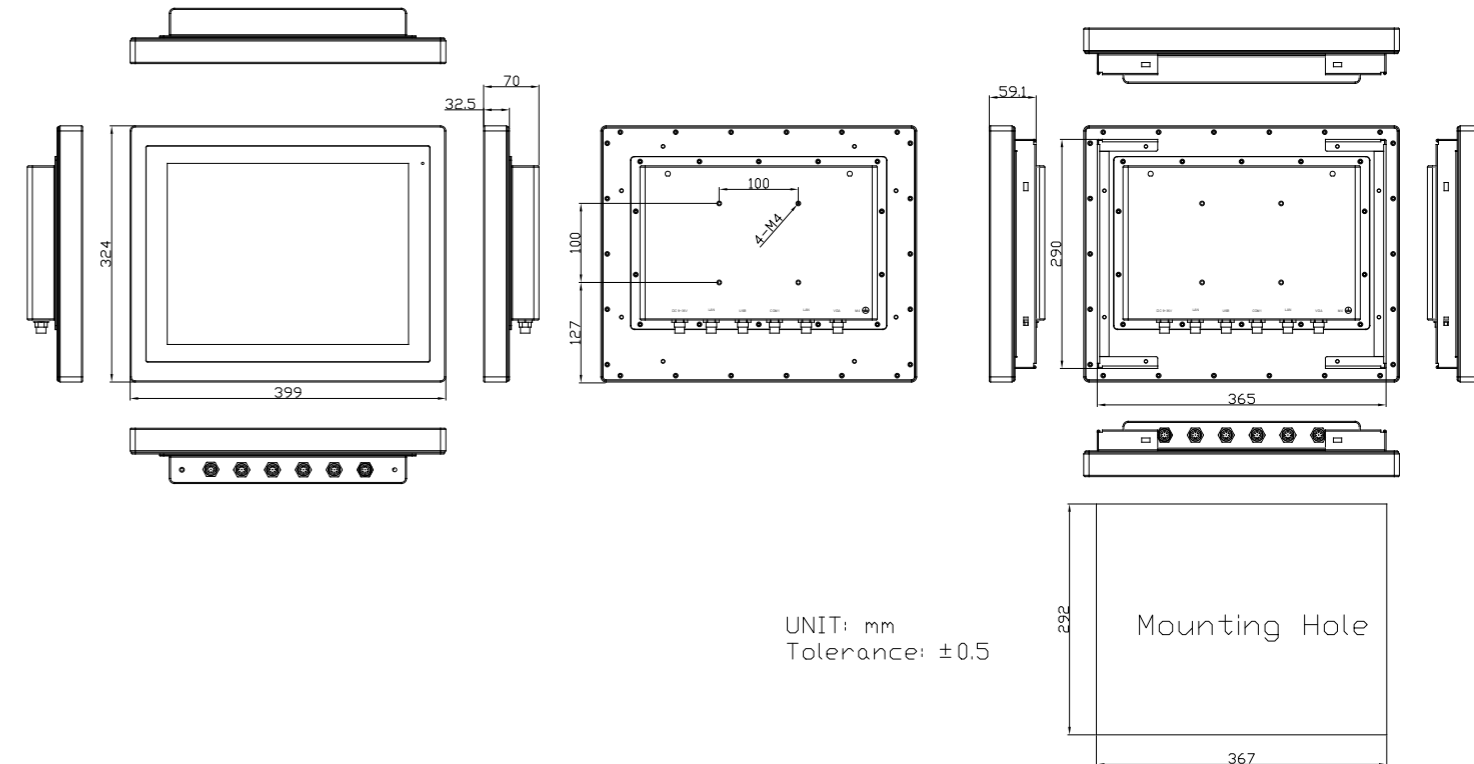

Environmental	
Operating Temperature	-20~60°C
Storage Temperature	-30~70°C
Storage Humidity	10 to 90% @ 40°C, non- condensing
Safety	CSA C22.2 No.61010
Certificate	CE / FCC Class A, ATEX Zone2 Ex nA ic IIC T4 Gc Class I, Division2, Group ABCD T4 ANSI/ISA 12.12.01-2013 CSA Std. C22.2 No213-1987

Operating System Support	
Windows embedded 7	
Windows embedded 8.1	
Windows 10 IoT ENT LTSB	

Ordering Information	
AEX-915AP	15" XGA IP66 Intel Core I5-6300U 2.4GHz, fan less panel PC, 1 x SO-DIMM(260pins), Up to 16G DDR4 2400MHz, 1 x 256GB 2.5" MLC SSD, 1 x 64GB mSATA MLC SSD, Projected capacitive touch, DC9~36V power input with power adapter, 316 stainless steel enclosure, support VESA Mount, WT-20~60 Accessory : 1 x M12 for 2 x USB2.0 Cable, 2 x M12 LAN cable, 1 x M12 COM Cable, 1 x VGA Cable, 1 x 3pin power input cable (w/o Adapter)
AEX-915APH	15" XGA HB1000nits IP66 Intel Core I5-6300U 2.4GHz, fan less panel PC, 1 x SO-DIMM(260pins), Up to 16G DDR4 2400MHz, 1 x 256GB 2.5" MLC SSD, 1 x 64GB mSATA MLC SSD, Projected capacitive touch, DC9~36V power input with power adapter, 316 stainless steel enclosure, support VESA Mount, WT-20~60 Accessory : 1 x M12 for 2 x USB2.0 Cable, 2 x M12 LAN cable, 1 x M12 COM Cable, 1 x VGA Cable, 1 x 3pin power input cable (w/o Adapter)

VIVATECH LLC  
Sharjah Media City, Sharjah, UAE  
Call: +97 1589584527  
Call: +91 9004784527  
Email : [sales@vivatech.ae](mailto:sales@vivatech.ae)  
Website : [www.vivatech.ae](http://www.vivatech.ae)

